

THIS DRAWING IS UNPUBLISHED.

RELEASED FOR PUBLICATION

ALL RIGHTS RESERVED.

© COPYRIGHT - By -

LOC AF DIST 50

REVISIONS

| P | LTR | DESCRIPTION | DATE | DWN | APVD |
|----|-----|-----------------------|---------|-----|------|
| G2 | | REV PER ECO 11-020508 | 11OCT11 | JR | TM |

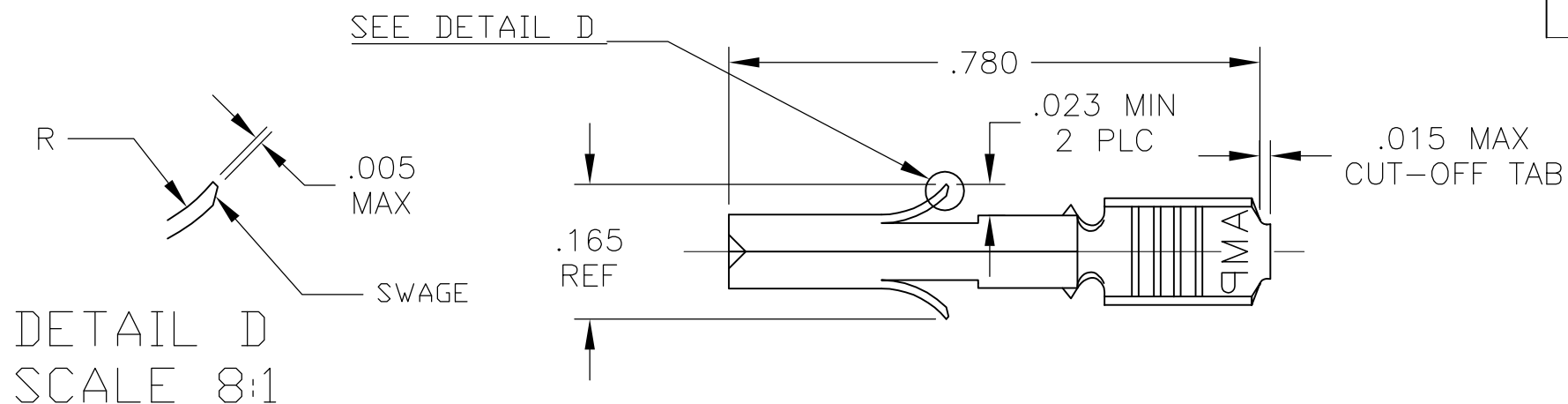

- WIRE RANGE : 12-10 AWG
INSULATION RANGE: .200 DIA MAX
(LIMITED BY THE CONNECTOR HOUSING CAVITY).
- .000030 THK GOLD, OVER .000050 NICKEL UNDERPLATE ON INSIDE OF RECEPTACLE, REMAINDER OF CONTACT IS NICKEL PLATED.

DETAIL D
SCALE 8:1

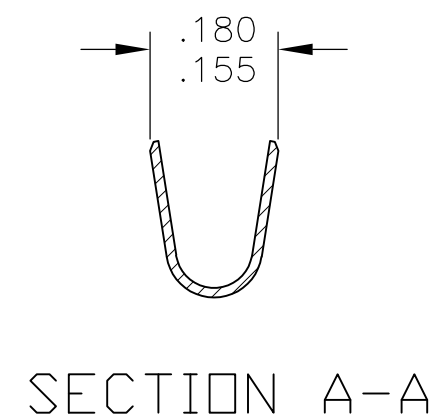
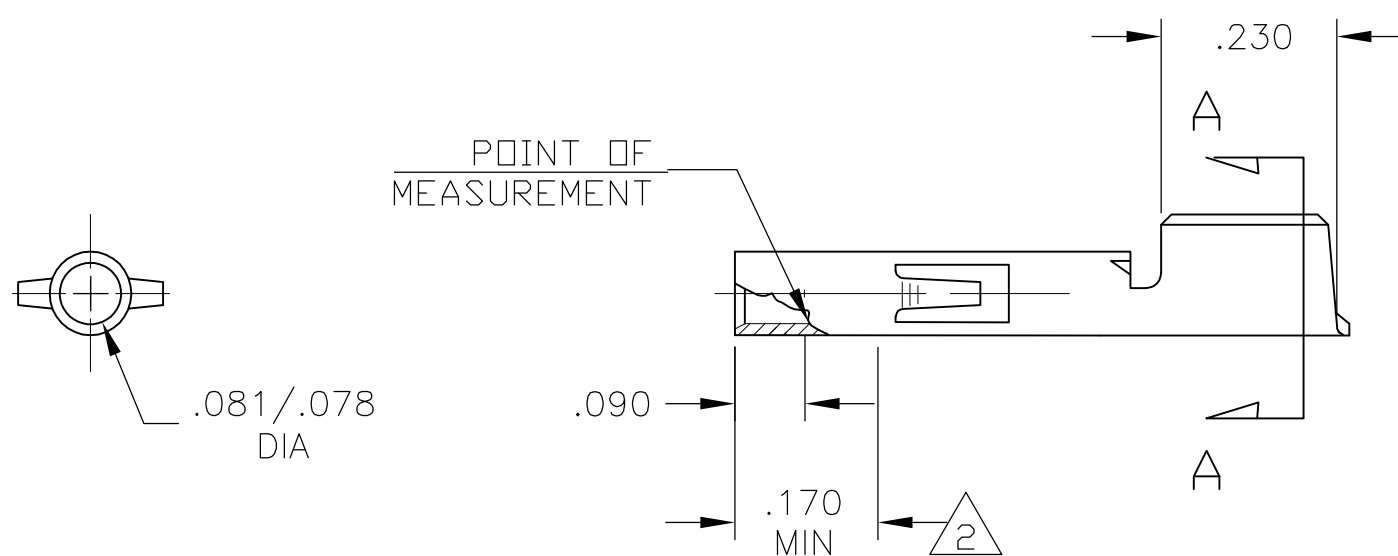

| | | |
|--------------------|--------------------|-------------|
| GOLD \triangle_2 | .012±.001 PHOS BRZ | 640310-6 |
| PRE-TIN | .012±.001 PHOS BRZ | 640310-3 |
| FINISH | MATERIAL | PART NUMBER |

| | | | | | | | | | | | | | | |
|---|----------|------------------------------|---|-----------------|---------------------|-------|-----|-------|-----|-------|--------|-------|-----|--------|
| THIS DRAWING IS A CONTROLLED DOCUMENT. | | DWN jr_ruth 11OCT11 | TE Connectivity | | | | | | | | | | | |
| DIMENSIONS: INCHES | | CHK TOM MICHIELUTTI 11OCT11 | | | | | | | | | | | | |
| TOLERANCES UNLESS OTHERWISE SPECIFIED: | | APVD TOM MICHIELUTTI 11OCT11 | | | | | | | | | | | | |
| <table border="1"> <tr><td>0 PLC</td><td>± -</td></tr> <tr><td>1 PLC</td><td>± -</td></tr> <tr><td>2 PLC</td><td>± -</td></tr> <tr><td>3 PLC</td><td>± .010</td></tr> <tr><td>4 PLC</td><td>± -</td></tr> <tr><td>ANGLES</td><td>± -</td></tr> </table> | | 0 PLC | | | ± - | 1 PLC | ± - | 2 PLC | ± - | 3 PLC | ± .010 | 4 PLC | ± - | ANGLES |
| 0 PLC | ± - | | | | | | | | | | | | | |
| 1 PLC | ± - | | | | | | | | | | | | | |
| 2 PLC | ± - | | | | | | | | | | | | | |
| 3 PLC | ± .010 | | | | | | | | | | | | | |
| 4 PLC | ± - | | | | | | | | | | | | | |
| ANGLES | ± - | | | | | | | | | | | | | |
| MATERIAL - | FINISH - | PRODUCT SPEC - | SOCKET UNIVERSAL MATE-N-LOK LOOSE PIECE | | | | | | | | | | | |
| | | APPLICATION SPEC - | SIZE A3 | CAGE CODE 00779 | DRAWING NO C-640310 | | | | | | | | | |
| | | WEIGHT - | RESTRICTED TO - | | | | | | | | | | | |
| | | CUSTOMER DRAWING | SCALE 4:1 | SHEET 1 OF 1 | REV G2 | | | | | | | | | |