

LOC	DIST	REVISIONS					
AF	50	P	LTR	DESCRIPTION	DATE	DWN	APVD
		G		REVISED PER ECR-06-010412	08NOV06	HMR	KR

- 1 CONTINUOUS STRIP ON REELS WITH TERMINALS LOCATED ON 8.38±0.08 [.330±.003] CENTERS.
- 2 SLOT TERMINATES A SINGLE COPPER MAGNET WIRE. WIRE RANGE: 0.64-0.81mm [#22-#20] AWG.
- 3 0.002032 [.000080] MIN TIN PLATE.

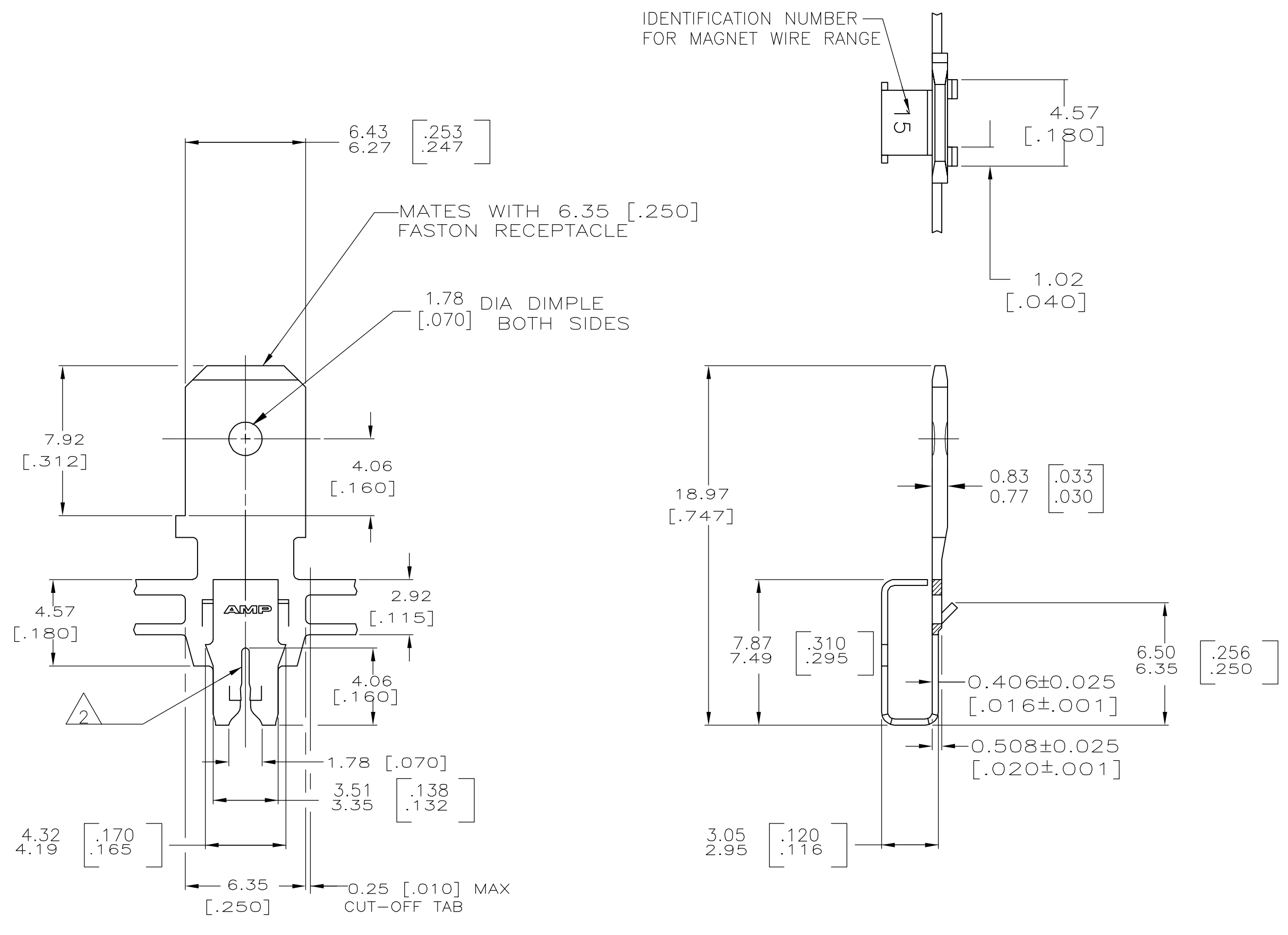

	082 PRE-MILLED BRASS	63601-2
OBSELETE	<del>4M PRE-MILLED BRASS</del>	<del>63601-1</del>
	MATERIAL	PART NUMBER

THIS DRAWING IS A CONTROLLED DOCUMENT.		DWN MICHAEL S. FEHER 14JAN2005	Tyco Electronics Corporation Harrisburg, PA 17105-3608	
DIMENSIONS: mm [INCHES]		CHK KURT A. RANDOLPH 14JAN2005	NAME KURT A. RANDOLPH	
TOLERANCES UNLESS OTHERWISE SPECIFIED:		APVD KURT A. RANDOLPH 14JAN2005	PRODUCT SPEC 108-2012	
0 PLC ± -		APPLICATION SPEC 114-2094		
1 PLC ± -		SIZE A2		
2 PLC ± -		CAGE CODE 00779		
3 PLC ± 0.25 [.010]		DRAWING NO G-63601		
4 PLC ± -		RESTRICTED TO -		
ANGLES ± -		WEIGHT -		
FINISH		SCALE 5:1		
SEE TABLE		SHEET 1 of 1		
3		REV G		
CUSTOMER DRAWING				