

THIS DRAWING IS UNPUBLISHED. RELEASED FOR PUBLICATION
 © COPYRIGHT BY TYCO ELECTRONICS CORPORATION. ALL RIGHTS RESERVED.

LOC	DIST	REVISIONS					
GP	00	P	LTR	DESCRIPTION	DATE	DWN	APVD
		A		REV PER EC 0S12-0573-04	05-04-05	JA	SF

.050±.005 DIA

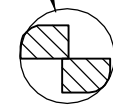

SECTION A-A

SCALE 10:1
10 PLACES

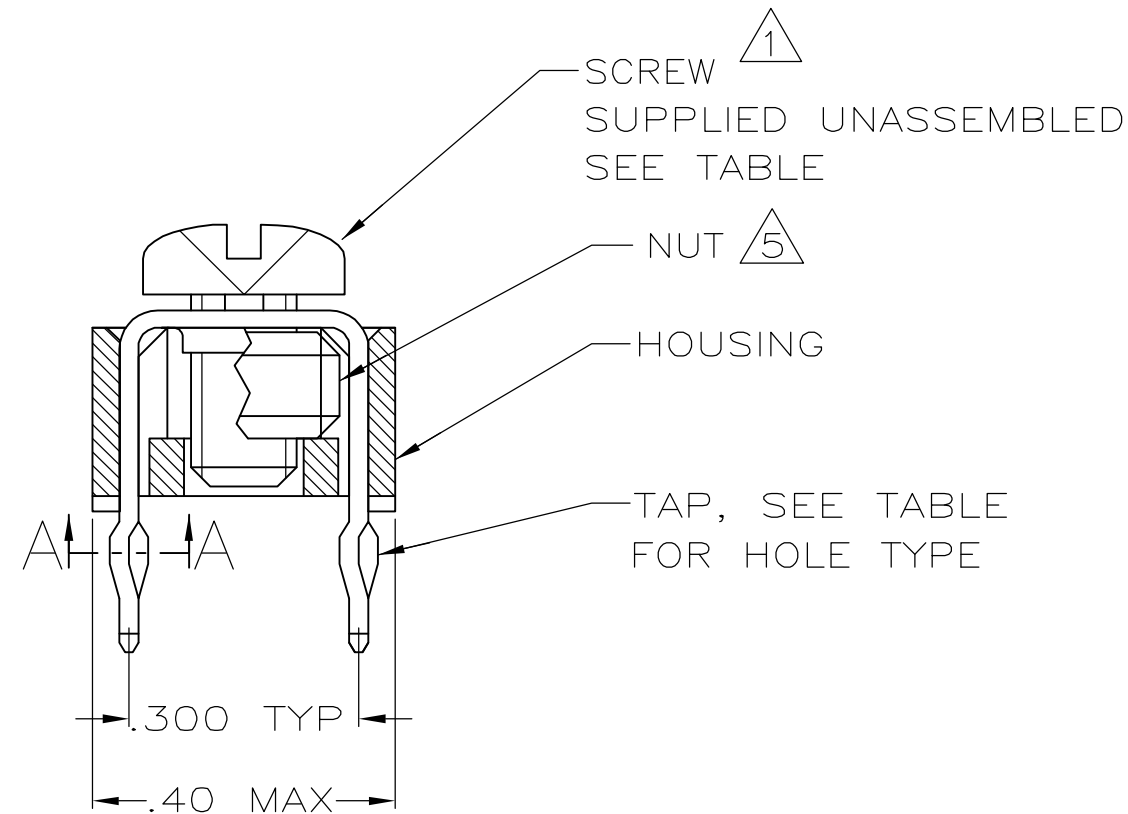
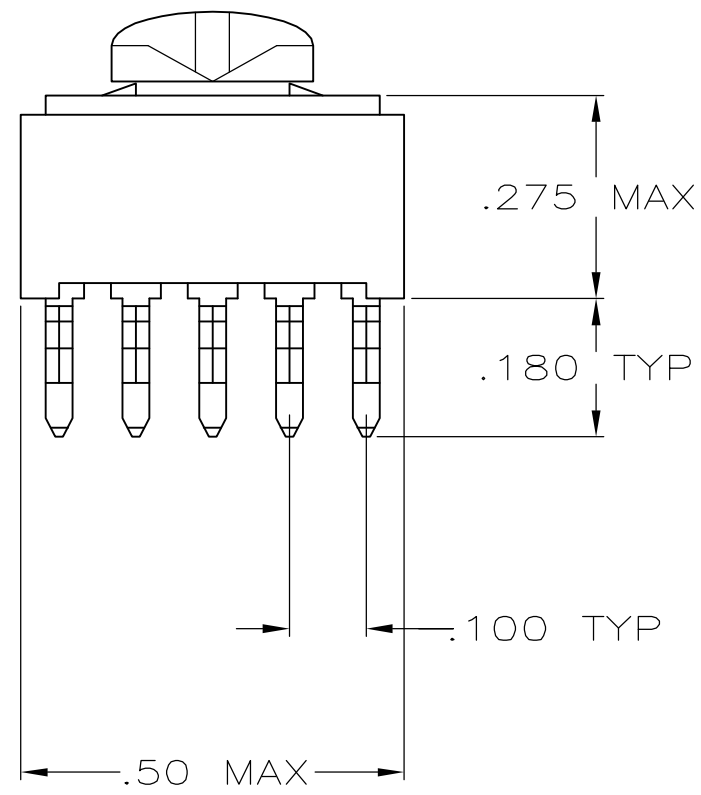

- ① TO PREVENT THREAD STRIPPING, SCREW TORQUE SHOULD NOT EXCEED 9 IN LBS.
- ② TAP HOLE IS 6-32UNC-2B, TWO MIN THREADS.
- ③ TAP HOLE IS M4 X 0.7, TWO MIN THREADS.
- ④ PACKAGED BULK.
- ⑤ NUT INCREASES TORQUE VALUE TO 26 IN LBS.
- ⑥ HOUSING: NYLON UL 94V-0. TAP: COPPER ALLOY 735, .025 THICK.
- ⑦ TAP: .000150 MATTE TIN OVER .000050 NICKEL.
- ⑧ CLEARANCE HOLE FOR A 6-32 SCREW.
- ⑨ REFERENCE APPLICATION SPECIFICATION 114-11000 FOR DRILL HOLE SIZES AND FINISHES

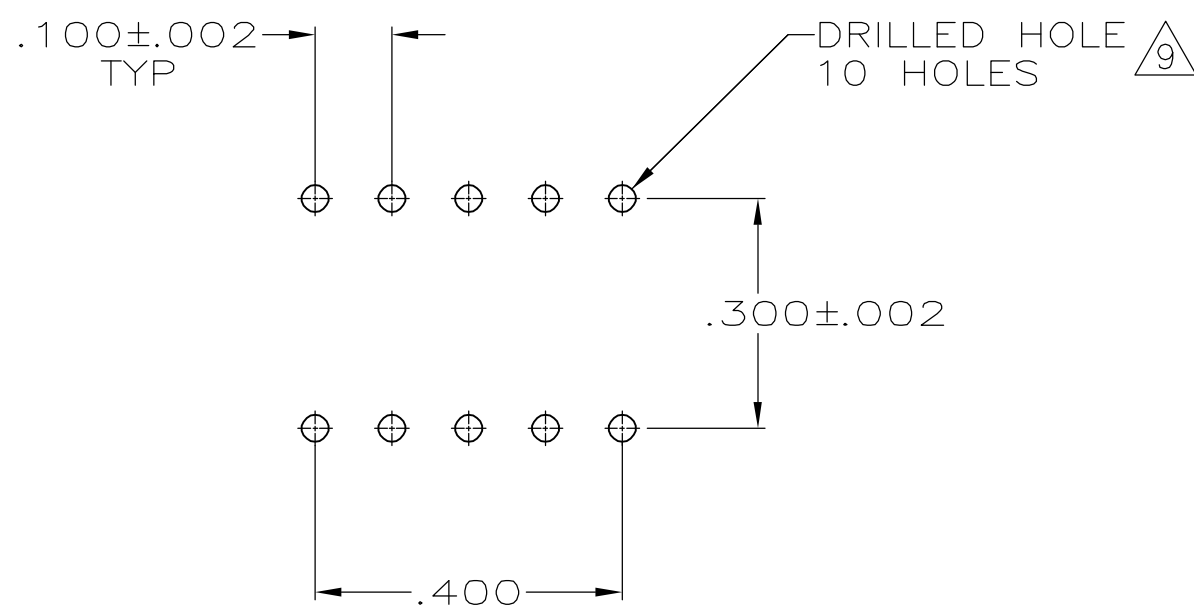

PC BOARD PATTERN

④	⑦	⑧	BLACK	⑤ YES (W/NUT)	NO	1-5055556-3
④	⑦	⑧	BLACK	⑤ YES (W/NUT)	993879-1	1-5055556-2
④	⑦	③	BLACK	YES	M4 X 0.7 X 6MM	5055556-9
④	⑦	②	BLACK	YES	993879-1	5055556-4
④	⑦	②	BLACK	YES	NO	5055556-3
PACKAGE	FINISH	HOLE TYPE	HOUSING COLOR	HOUSING AND TAP ASSEMBLED	SCREW	PART NO.

THIS DRAWING IS A CONTROLLED DOCUMENT.

DWN J. ALCORTA - DOCK5 05-04-05	 Tyco Electronics Corporation Harrisburg, PA 17105-3608
CHK A. FRANTUM 05-04-05	
APVD S. FLICKINGER 05-04-05	NAME
PRODUCT SPEC 108-11030	TAP ASSEMBLY, POWER DISTRIBUTION
APPLICATION SPEC 114-11000	
MATERIAL ⑥	FINISH
WEIGHT	
CUSTOMER DRAWING	
SIZE A2	CAGE CODE 00779
DRAWING NO C=5055556	RESTRICTED TO
SCALE 4:1	SHEET 1 OF 1
REV A	