

**PROPER USE GUIDELINES**

Cumulative Trauma Disorders can result from the prolonged use of manually powered hand tools. Hand tools are intended for occasional use and low volume applications. A wide selection of powered application equipment for extended-use, production operations is available.

ORIGINAL INSTRUCTIONS

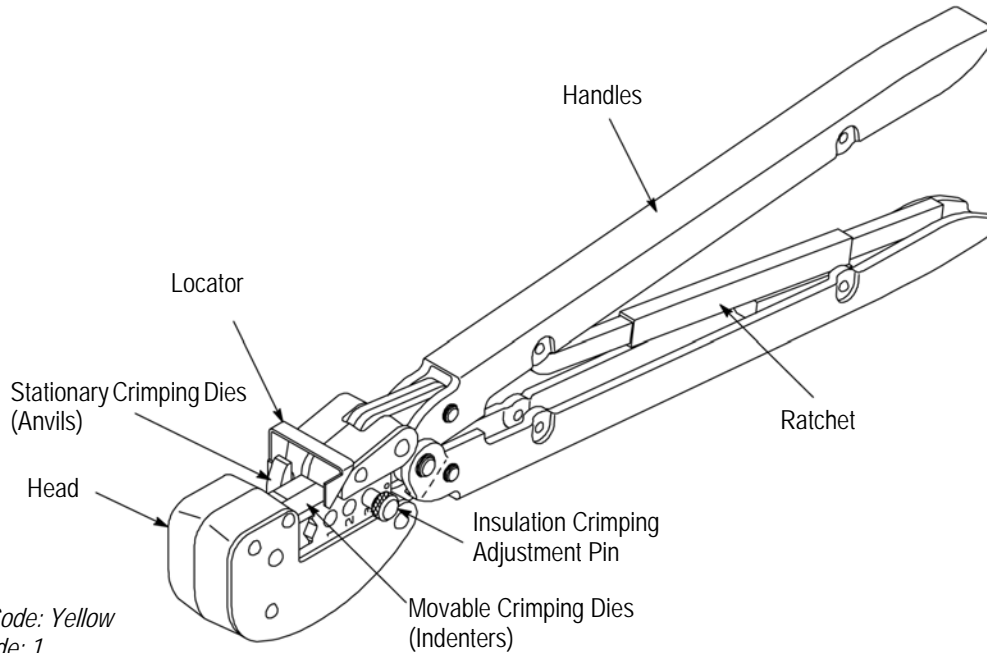

Tool Color Code: Yellow  
Tool Dot Code: 1

TOOL	PRODUCT		WIRE		
	TYPE	INSULATION COLOR CODE	TYPE	SIZE (AWG)	INSULATION DIAMETER (mm [in.])
59239-4 59239-8 525692	PIDG* Vinyl and Nylon Terminal and Splice and PLASTI-GRIP* Terminal	Yellow	Solid or Stranded Copper	12 - 10	5.84-6.35 [.230-.250]
		Yellow w/ Black stripes		16 - 14 ‡	
	PIDG Insulation Restraining Nylon Terminal	Yellow w/ 3 Yellow Stripes	Stranded Copper	12	2.41-5.08 [.095-.200]
		Yellow w/ 3 Brown Stripes		10	3.02 - 5.08 [.119 - .200]
	PIDG Radiation Resistant Terminal and Splice	Natural with Yellow Stripe	Stranded Copper	12 - 10	6.60 [.260] Max
Natural with Yellow Stripe		16 - 14 ‡			
Spare Wire Cap 328309	Yellow	Stranded Copper	12 - 10	5.33 [.210] Max	
59287-2	PIDG Vinyl and Nylon Terminal and Splice and PLASTI-GRIP Terminal	Yellow	Solid or Stranded Copper	12 - 10	6.99-7.62 [.275-.300]
		Yellow w/ Black Stripe		16 - 14 ‡	

‡ Heavy Duty

Figure 1

## 1. INTRODUCTION

Heavy Head Hand Tools (HHHT) 525692, 59239-4, 59239-8, and 59287-2 are designed to crimp the product listed in Figure 1 onto the wire also listed.



*Dimensions are in metric units [with U.S. customary units in brackets]. Figures and illustrations are for reference only and are not drawn to scale.*

For other tools accompanied by this instruction sheet, follow the instructions for the tool used to crimp the same wire size.

Reasons for reissue of this instruction sheet are provided in Section 7, REVISION SUMMARY.

## 2. DESCRIPTION

Each tool consists of a head containing two stationary crimping dies (anvils) and two movable crimping dies (indenters), a locator, an insulation crimping adjustment pin, and handles with a ratchet. See Figure 1.

These tools are members of the CERTI-CRIMP\* hand crimping tool family. The ratchet on these tools ensures full crimping of the product. Once engaged, the ratchet will not release until the handles have been FULLY closed.

When closed, the crimping dies form a crimping chamber with two sections: an insulation barrel section and a wire barrel section. The insulation barrel section crimps the insulation barrel of the product onto the wire insulation and, simultaneously, the wire barrel section crimps the wire barrel of the product onto the wire conductor(s).

The crimping dies bottom before the ratchet releases. This design ensures maximum electrical and tensile performance of the crimp. DO NOT re-adjust the ratchet.

The locator positions the product in the crimping chamber. The insulation crimping adjustment pin is used to regulate the height of the insulation crimp.

Each tool handles are color coded (yellow) to correspond to the color code of the product. Each tool produces a dot code (one dot) on the crimp to correspond to the given wire size range. Refer to Figure 2.

## 3. CRIMPING PROCEDURE

### 3.1. Wire Preparation

Strip the wire within the dimensions given in Figure 3, being careful to avoid nicking or damaging the wire conductor(s).



*DO NOT use wire with nicked or missing conductor(s).*

### 3.2. Crimping

Make sure that the insulation color code of the product matches the color of the tool handles. Refer to Figure 1.

#### A. Terminals

1. Insert the insulation crimp adjustment pin in the proper position according to Section 4.
2. Open the crimping dies by closing the tool handles until the ratchet releases, then allow the handles to open FULLY.
3. Place the terminal in the crimping chamber so that the wire barrel butts against the locator. Refer to Figure 4.

### Product Color Code

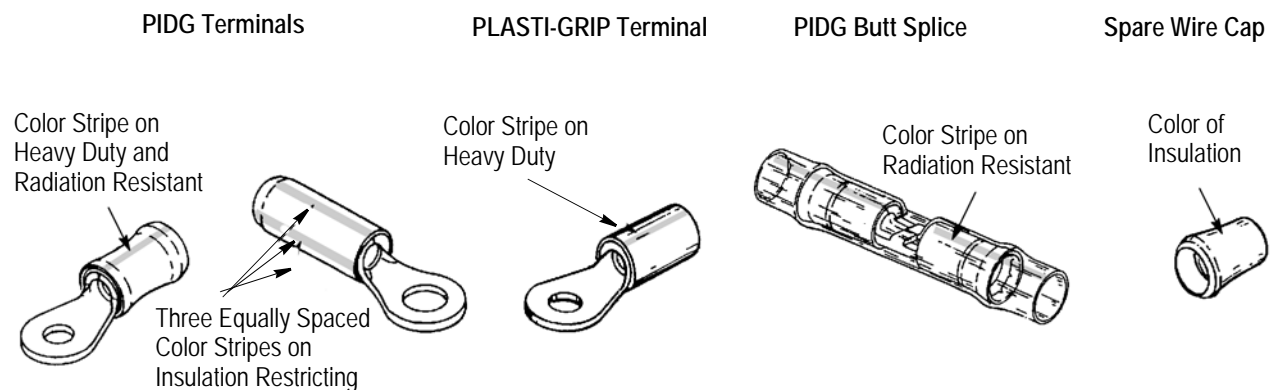

Figure 2

4. Close the tool handles until the terminal is held firmly in place. DO NOT deform the terminal.

5. Insert a properly stripped wire into the terminal wire barrel until the end of the wire conductor(s) butts against the locator.



DO NOT allow the wire insulation to enter the terminal wire barrel.

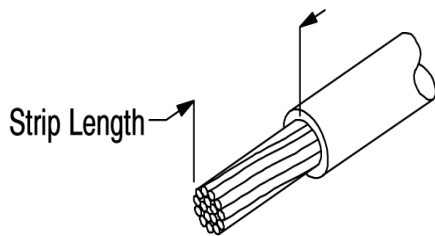

PRODUCT	WIRE STRIP LENGTH
PIDG Vinyl and Nylon Terminal, PLASTI-GRIP Terminal, and PIDG Radiation Resistant Terminal	7.94-8.73 [.312-.344]
PIDG Insulation Restricting Nylon Terminal	9.65-10.4 [.380-.410]
PIDG Vinyl and Nylon Splice and PIDG Radiation Resistant Splice	8.64-9.65 [.340-.380]
Spare Wire Cap	8.64-9.65 [.340-.380]

Figure 3

6. Complete the crimp by closing the tool handles until the ratchet releases.

7. Release the tool handles, allow the handles to open FULLY, and remove the crimped terminal.

8. Inspect the crimp to make sure that it conforms to Figures 7 and 8. Terminals not meeting the described conditions should NOT be used.

## B. Butt Splices

1. Open the crimping dies by closing the tool handles until the ratchet releases, then allow the handles to open FULLY.

2. Depress the locator. Position the splice in the crimping chamber so that window indent of the splice seats over the locator. See Figure 5.

3. Close the tool handles until the splice is held firmly in place. DO NOT deform the splice.

4. Insert a properly stripped wire into the wire barrel of the splice until the end of the wire conductor(s) butts against the splice wire stop.

## Crimping A Terminal

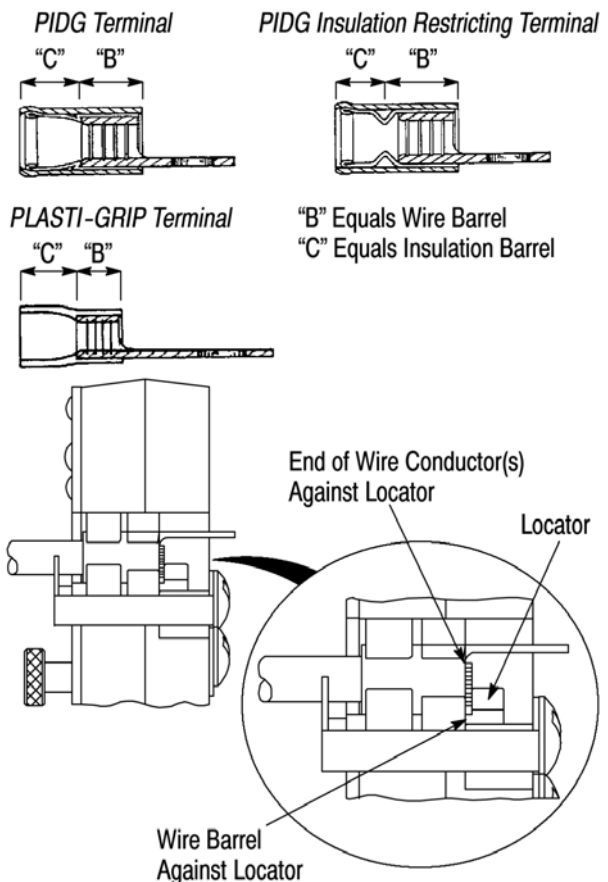

Figure 4

## Crimping a Butt Splice

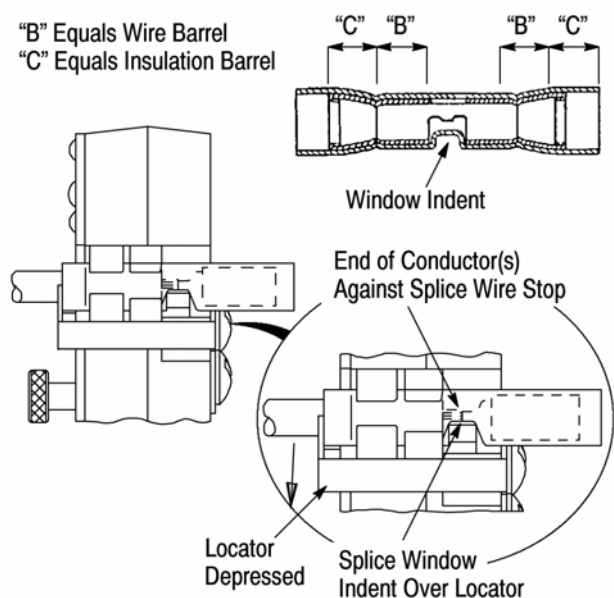

Figure 5



*DO NOT allow wire insulation to enter the splice wire barrel.*

5. Complete the crimp by closing the tool handles until the ratchet releases.
6. Release the tool handles, allow the handles to open FULLY, and remove the crimped splice.
7. Turn the splice around, depress the locator, and position the splice in the crimping chamber so that the window indent of the splice seats over the locator. Follow Steps 3 through 6.
8. Inspect the crimp to make sure that it conforms to Figures 7 and 8. Splices not meeting the described conditions should NOT be used.

### C. Spare Wire Cap

1. Place the tool insulation adjustment pins in the Position 3.
2. Close the tool handles until the crimping dies partially close, but leave enough space for the spare wire cap to be inserted in the crimping chamber.
3. Depress the locator so that the end of the spare wire cap rests against the recessed surface of the locator. See Figure 6.
4. Close the tool handles until the spare wire cap is held firmly in place. Do NOT deform the spare wire cap.

5. Insert a properly stripped wire into the spare wire cap until the wire conductor(s) bottoms.
6. Hold the wire in position, and complete the crimp by closing the tool handles until the ratchet releases.
7. Release the tool handles, allow the handles to open FULLY, and remove the crimped spare wire cap.
8. Inspect the crimp to make sure that it conforms to Figures 7 and 8. Spare wire caps not meeting the described conditions should NOT be used.

### 4. INSULATION CRIMP ADJUSTMENT

The insulation crimping section of the hand tool has three positions: 1 (tight), 2 (medium), and 3 (loose).

To adjust the grip resulting from the crimp of the insulation barrel, proceed as follows:

#### 4.1. PIDG Terminal and Splice

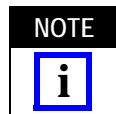

*PIDG terminals and splices feature a wire insulation grip.*

1. Insert each insulation crimp adjustment pin into Position 3. Refer to Figure 1.



*Make sure that both insulation crimp adjustment pins are in the same position.*

2. Place the terminal or splice into the crimping chamber as described in Section 3.
3. Insert an UNSTRIPPED wire into ONLY the insulation barrel of the terminal or splice.
4. Close the tool handles until the ratchet releases.
5. Release the tool handles, and allow the handles to open FULLY. Remove the crimped terminal or splice.
6. Check the insulation barrel crimp by bending the wire back and forth once. The terminal or splice should retain its grip on the wire insulation. If it does not, insert each insulation crimp adjustment pin into the next position (Position 2).
7. Repeat Steps 2 through 6 until the correct insulation barrel grip is attained. DO NOT use a tighter position than is necessary.

#### 4.2. PLASTI-GRIP Terminal

PLASTI-GRIP terminals and splices feature a wire "insulation support" only. Ideally, the terminal or splice insulation should be in contact with the wire insulation.

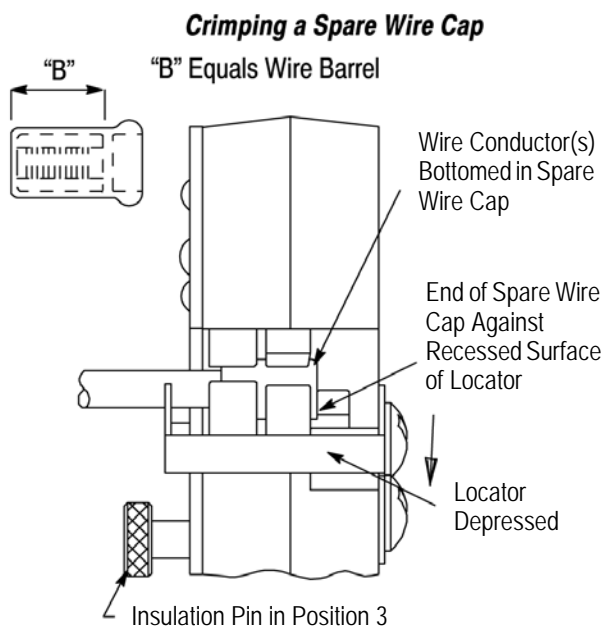

Figure 6

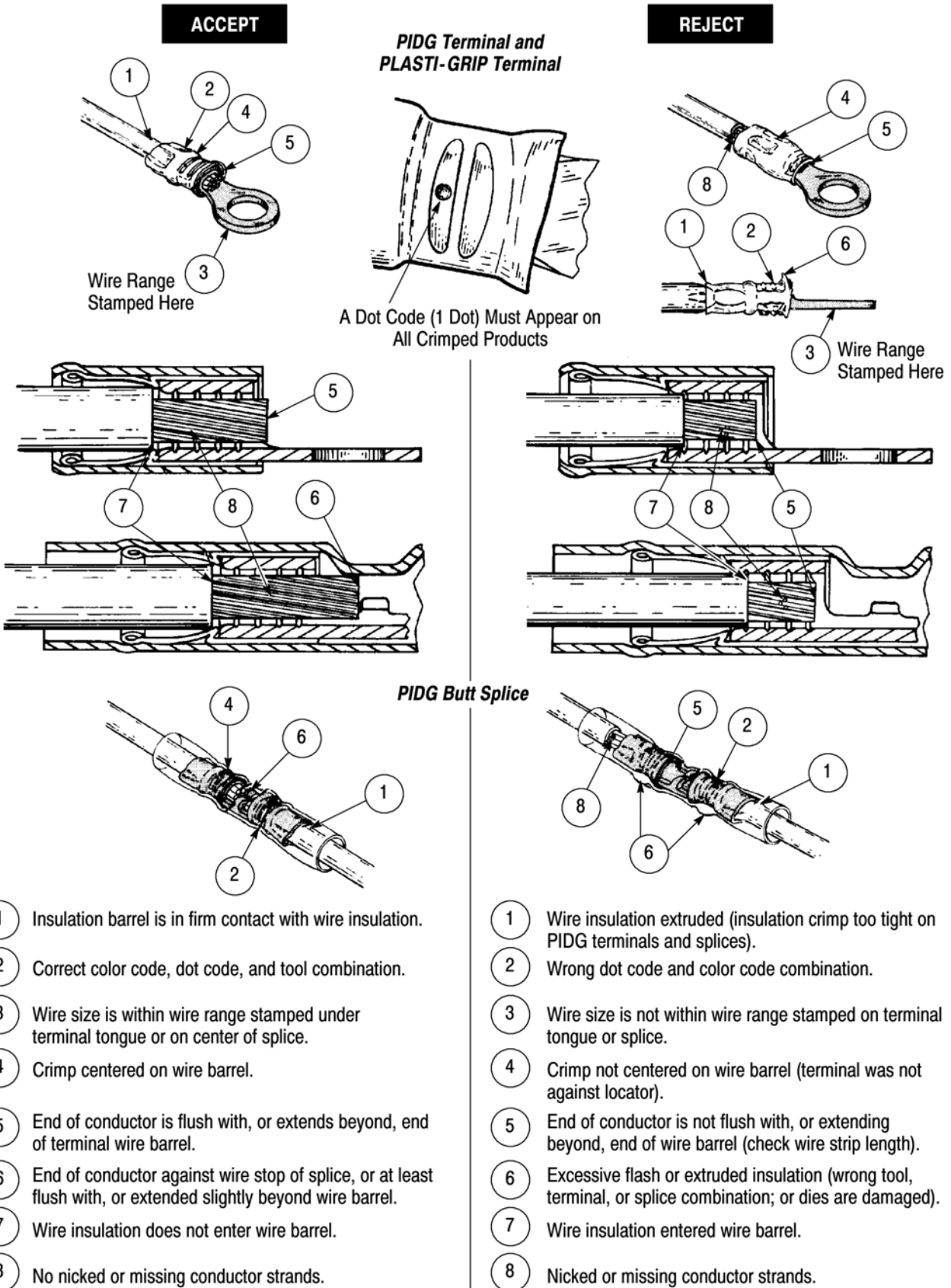

Figure 7

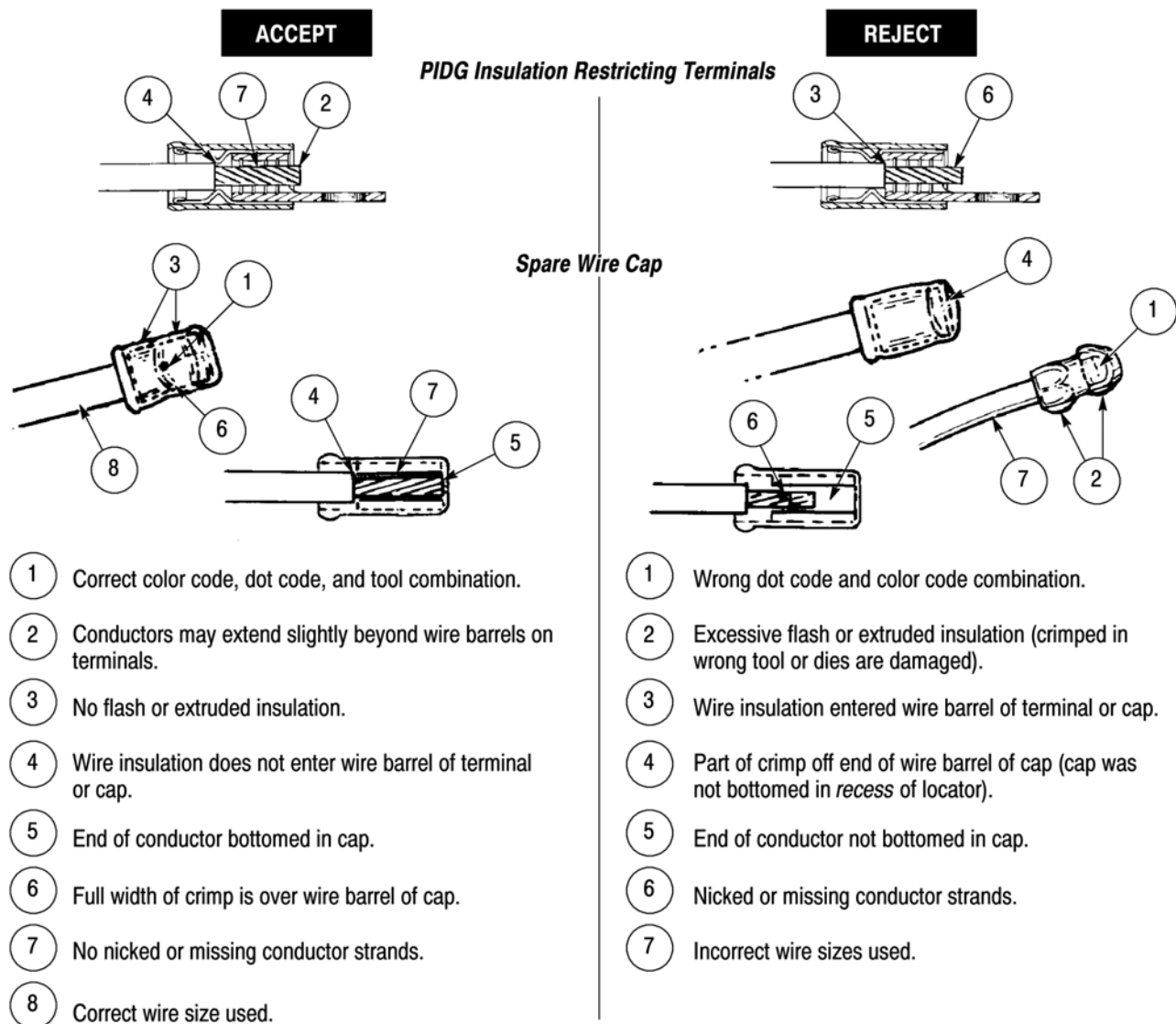

Figure 8

Insert each insulation crimp adjustment pin into position according to the following:



*Make sure that both insulation crimp adjustment pins are in the same position.*

- Position 3 for wire having a large insulation diameter.
- Position 2 for wire having a medium insulation diameter.
- Position 1 for wire having a small insulation diameter.

## 5. MAINTENANCE AND INSPECTION

It is recommended that a maintenance and inspection program be performed periodically to ensure

dependable and uniform terminations. Though recommendations call for at least one inspection a month, frequency of inspection depends on:

1. The care, amount of use, and handling of the tool.
2. The presence of abnormal amounts of dust and dirt.
3. The degree of operator skill.
4. Your own established standards.

The tool is inspected before being shipped; however, it is recommended that the tool be inspected immediately upon arrival to ensure that the tool has not been damaged during shipment.

## 5.1. Daily Maintenance

1. Immerse the tool (handles partially closed) in a reliable commercial degreasing compound to remove accumulated dirt, grease, and foreign matter. When degreasing compound is not available, the tool may be wiped clean with a soft, lint-free cloth. **DO NOT** use hard or abrasive objects that could damage the tool.
2. Make certain that the retaining pins are in place and that they are secured with retaining rings.
3. All pins, pivot points, and bearing surfaces should be protected with a THIN coat of any good SAE 20 motor oil. **DO NOT** oil excessively.
4. When the tool is not in use, keep the handles closed to prevent objects from becoming lodged in the crimping dies. Store the tool in a clean, dry area.

## 5.2. Periodic Inspection

### A. Lubrication

Lubricate all pins, pivot points, and bearing surfaces with any good SAE† 20 motor oil as follows:

- Tool used in daily production - daily
- Tool used daily (occasional) - weekly
- Tool used weekly - monthly

Wipe excess oil from the tool, particularly from the crimping area. Oil transferred from the crimping area onto certain terminations may affect the electrical characteristics of an application.

### B. Visual Inspection

1. Close the tool handles until the ratchet releases and then allow them to open freely. If they do not open quickly and fully, the spring is defective and must be replaced. See Section 6, **REPLACEMENT AND REPAIR**.

#### NOTE



*Some tools do not have handle return springs. This inspection does not apply to those tools.*

2. Inspect the head for worn, cracked, or broken crimping dies. If damage is evident, return the tool for evaluation and repair. See Section 6, **REPLACEMENT AND REPAIR**.

### C. Gaging the Crimping Chamber

This inspection requires the use of plug gages conforming to the dimensions provided in Figure 9.

To gage the crimping chamber, proceed as follows:

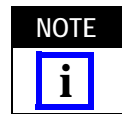

*If gaging the crimping chamber is not required, inspect the die closure using an alternate procedure, i.e., the "Insulation Crimp Adjustment" (see Section 4) and "Visual Inspection" (see Paragraph 5.2.B).*

1. Remove traces of oil or dirt from the crimping chamber and plug gage.
2. Insert each insulation crimp adjustment pin into Position 1. See Figure 10.
3. Close the tool handles until the crimping dies bottom, and hold in this position. **DO NOT** force beyond initial contact.
4. Press and hold the locator down.
5. Carefully insert the GO element into the crimping chamber as shown in Figure 10; **DO NOT** force it. For the wire barrel section of the crimping chamber, the GO element must pass completely through the crimping chamber. For the insulation barrel section, the GO element must pass through the length of the section but will stop against the wire barrel section.
6. In the same manner, try to insert the NO-GO element into the crimping chamber as shown in Figure 10. The NO-GO element may begin entry, but may not pass through the crimping chamber.

If the crimping chamber conforms to the gage inspection, the tool is considered dimensionally correct, and should be lubricated with a THIN coat of any good SAE 20 motor oil. If not, return the tool for evaluation and repair. See Section 6, **REPLACEMENT AND REPAIR**.

### 5.3. Ratchet Inspection

Check the ratchet to ensure that the ratchet does not release prematurely, allowing the dies to open before they have fully bottomed. Proceed as follows:

1. Remove traces of oil or dirt from the bottoming surfaces of the dies.
2. Obtain a 0.025 mm [.001 in.] shim that is suitable for checking the clearance between the bottoming surfaces of the dies.
3. Select a terminal or splice and maximum size wire for the terminal or splice.
4. Position the terminal or splice in the crimping chamber according to Section 3, **CRIMPING PROCEDURE**. Holding the wire in place, squeeze the tool handles together until the ratchet releases. Hold the tool handles in this position, maintaining just enough pressure to keep the dies closed.
5. Check the clearance between the bottoming surfaces of the dies. If the clearance is 0.025 mm [.001 in.] or less, the ratchet is satisfactory. If clearance exceeds 0.025 mm [.001 in.], the ratchet is out of adjustment and must be repaired. See Section 6, **REPLACEMENT AND REPAIR**.

†SAE is a trademark.

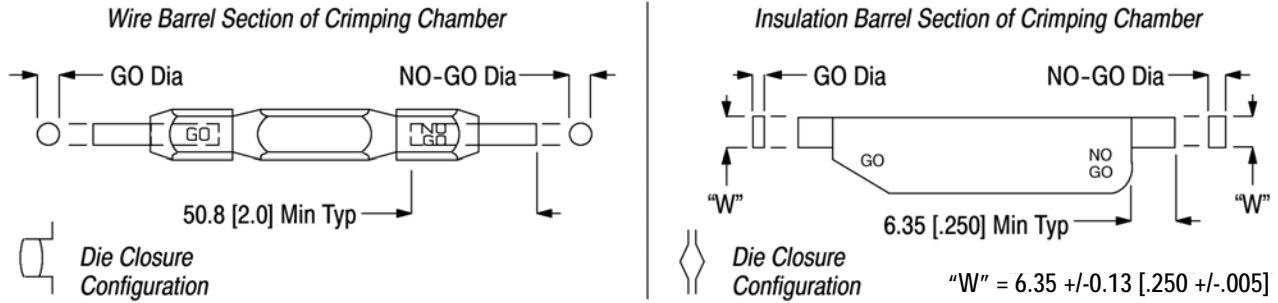
**Suggested Plug Gage Design**

GAGE ELEMENT DIAMETER		GAGE ELEMENT DIAMETER	
GO	NO-GO	GO	NO-GO
4.293-4.300 [.1690-.1693]	4.442-4.445 [.1749-.1750]	1.626-1.633 [.0640-.0643]	2.131-2.134 [.0839-.0840]

Figure 9

**Detail A  
Inspection of Wire Barrel  
Section of Crimping Chamber**

**Detail B  
Inspection of Insulation Barrel  
Section of Crimping Chamber**

Figure 10

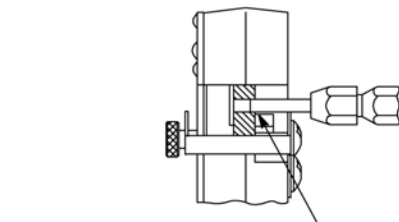
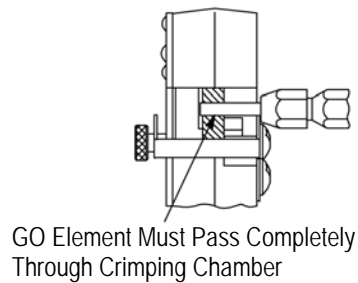
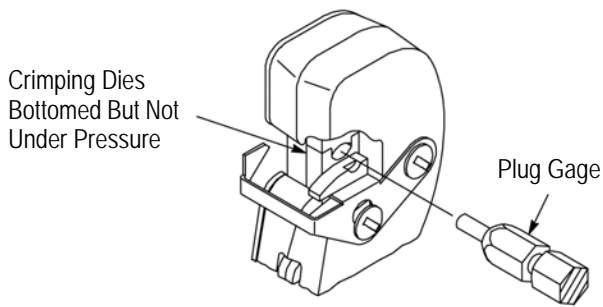
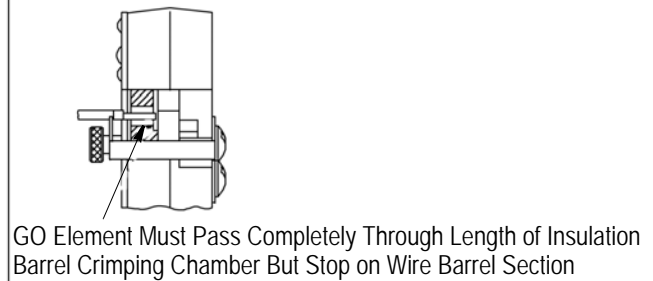
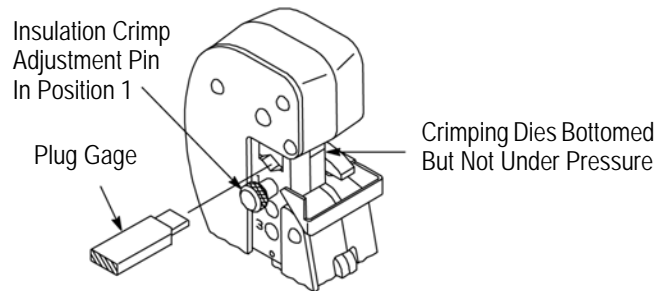

### 6. REPLACEMENT AND REPAIR

Customer-replaceable parts are listed in Figure 11.

A complete inventory should be stocked and controlled to prevent lost time when replacement of parts is necessary. Parts other than those listed should be replaced by TE Connectivity to ensure quality and reliability. Order replacement parts through your representative, or call 1-800-526-5142, or send a facsimile of your purchase order to 717-986-7605, or write to:

CUSTOMER SERVICE (038-035)  
 TYCO ELECTRONICS CORPORATION  
 PO BOX 3608  
 HARRISBURG PA 17105-3608

For customer repair service, call 1-800-526-5136.

### 7. REVISION SUMMARY

- Updated document to corporate requirements
- Added new information to Figures 9 and 10

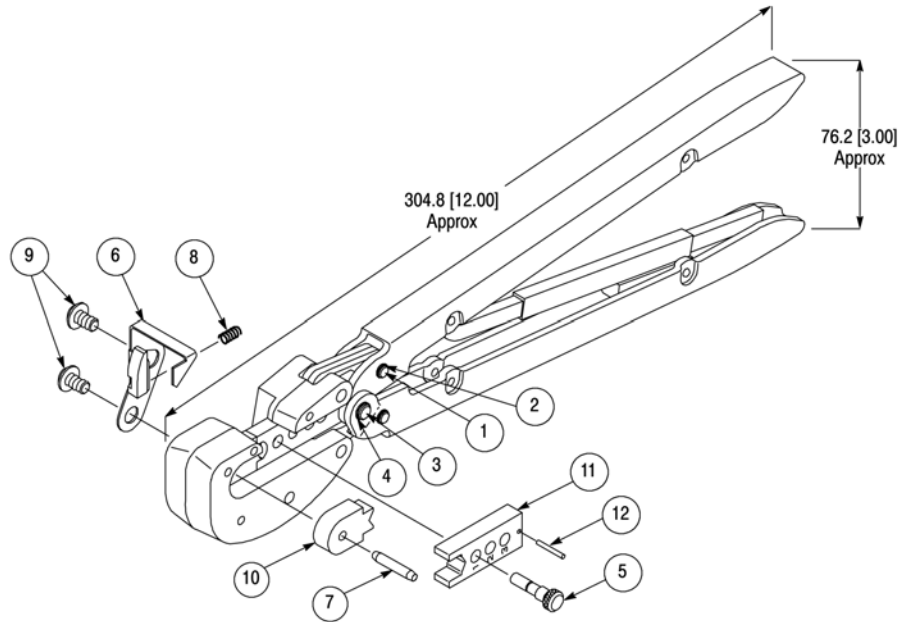

#### REPLACEMENT PARTS

ITEM	PART NUMBER FOR TOOL 306110-9			DESCRIPTION	QTY PER TOOL
	59239-4, 59239-8	59287-2	525692		
1	300388	300388	300388	PIN, Retaining	2
2	21045-3	21045-3	525108	RING, Retaining	4
3	300389	300389	300389	PIN, Retaining	1
4	21045-6	21045-6	21045-6	RING, Retaining	2
5	303848-2	303848-2	303848-2	PIN ASSEMBLY, Adjustment	1
6	306110-9	306110-4	306110-9	LOCATOR, Stop	1
7	5-21028-7	5-21028-7	5-21028-7	PIN	1
8	7-59683-6	7-59683-6	7-59683-6	SPRING	1
9	6-306131-4	6-306131-4	6-306131-4	SCREW	2
10	306106-2	45891-8	306106-2	STATIONARY DIE, Insulation	1
11	306107-2	45888-7	306107-2	MOVING DIE, Insulation	1
12	21028-4	21028-5	21028-4	PIN	1

Figure 11